

*Whole Cast Iron Grinder
Pump Series.*

G C Series



● *Bottom View of Chrome Steel Cutter*

FEATURES:

- For residential, industrial and municipal wastewater applications. All solids are reduced to particles allowing the use of small diameter piping connected to the conventional sewage system.

APPLICATIONS:

- For residential, industrial and municipal wastewater applications.





Performance

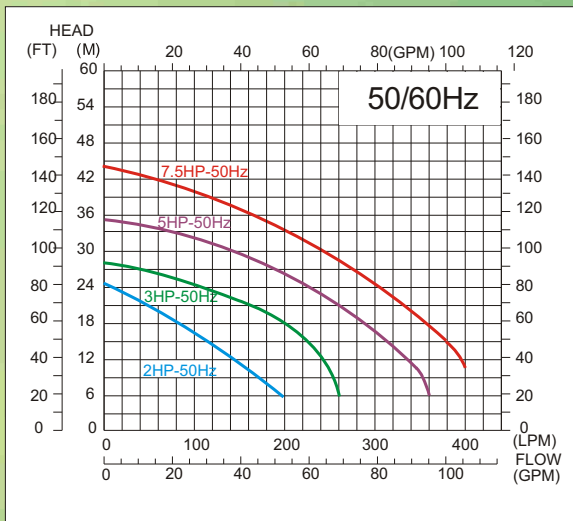

• Remarks: Guide Rail Pedestal is optional for 3 ~ 7.5 HP.

Construction

NO	Description	Material
1	Cable	SH07RNF
2	Hanger	Steel
3	Top Cover	Cast Iron
4	Top Seal Plate	Cast Iron
5	O-Ring	NBR
6	Upper Bearing	CNM5K
7	Oil Plug	SUS304
8	Rotor	S. Steel
9	Stator	S. Steel+Winding
10	Motor Housing	Cast Iron
11	Lower bearing	CNM5K
12	Mech. Seal	CA/CE
13	Impeller	Brass
14	Seal Plate	Cast Iron
15	brass Bearing	Brass
16	Base	Cast Iron
17	gear Seat	SUS304
18	Cutter	SUS304

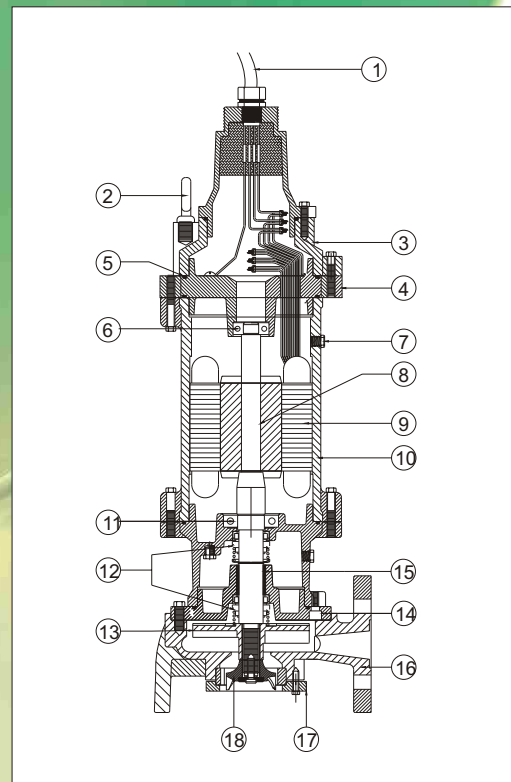

Specifications

Model	Output		Outlet		Rated		Maximum		Dimension	Weight	Hz	Phase
	HP	kW	mm	Inch	Head(M)	Flow(l/m)	Head(M)	Flow(l/m)	L x W x H (mm)	Kg		
GC-2051, GC-2053	2	1.5	32	1-1/4"	15	120	24	200	240x200x560	27KGS	50	1 ϕ or 3 ϕ
GC-2061, GC-2063	2	1.5	32	1-1/4"	15	120	24	200	240x200x560	27KGS	60	1 ϕ or 3 ϕ
GC-3053, GC-3063	3	2.2	50	2"	20	180	28	260	240x200x560	28KGS	50 or 60	3 ϕ
GC-5053, GC-5063	5	3.7	65	2-1/2"	25	220	36	360	270x238x830	94KGS	50 or 60	3 ϕ
GC-7553, GC-7563	7.5	5.5	65	2-1/2"	28	260	42	400	270x238x830	95.5KGS	50 or 60	3 ϕ



Hung Pump Group

16 Lien-Ming Street, Ba-De City 334,
 Taoyuan, Taiwan
 TEL:(886) -3-371-3969
 FAX:(886) -3-371-3996
 E-Mail: hungpump@ms9.hinet.net